

- NOTES:
1. ALL DIMENSIONS ARE IN MILLIMETERS AND LEVELS ARE IN METERS UNLESS OTHERWISE INDICATED.
 2. ALL CONCRETE TO BE GRADE M50 EXCEPT WHERE OTHERWISE STATED.
 3. SHAFTS ARE TO BE MADE WATER TIGHT.
 4. SEWER GRADIENTS TO BE MAINTAINED ACROSS MANHOLE.
 5. DIMENSIONS OF PERMANENT STRUCTURAL WORKS SHOWN ARE INDICATIVE. THE CONTRACTOR SHALL DESIGN THE PERMANENT STRUCTURAL WORKS TO THE APPROVAL OF THE ENGINEER, TO SUIT THE CONTRACTOR'S METHOD OF WORKING AND TEMPORARY WORKS. CONTRACTOR TO SUBMIT CONSTRUCTION METHODOLOGY OF TEMPORARY AND PERMANENT WORKS TO THE APPROVAL OF THE ENGINEER.
 6. SHAFT INTERNAL DIAMETER GIVEN IS THE MINIMUM TO BE PROVIDED.
 7. FINISHED GROUND LEVEL TO MATCH EXISTING ROAD LEVEL.
 8. SHAFT S12 LOCATION IS TENTATIVE, MCGM REQUESTED BEST FOR GIVING SPACE IN THE DEPOT FOR SHAFT CONSTRUCTION.
 9. INVERT LEVELS MAY VARY SLIGHTLY DURING EXECUTION.

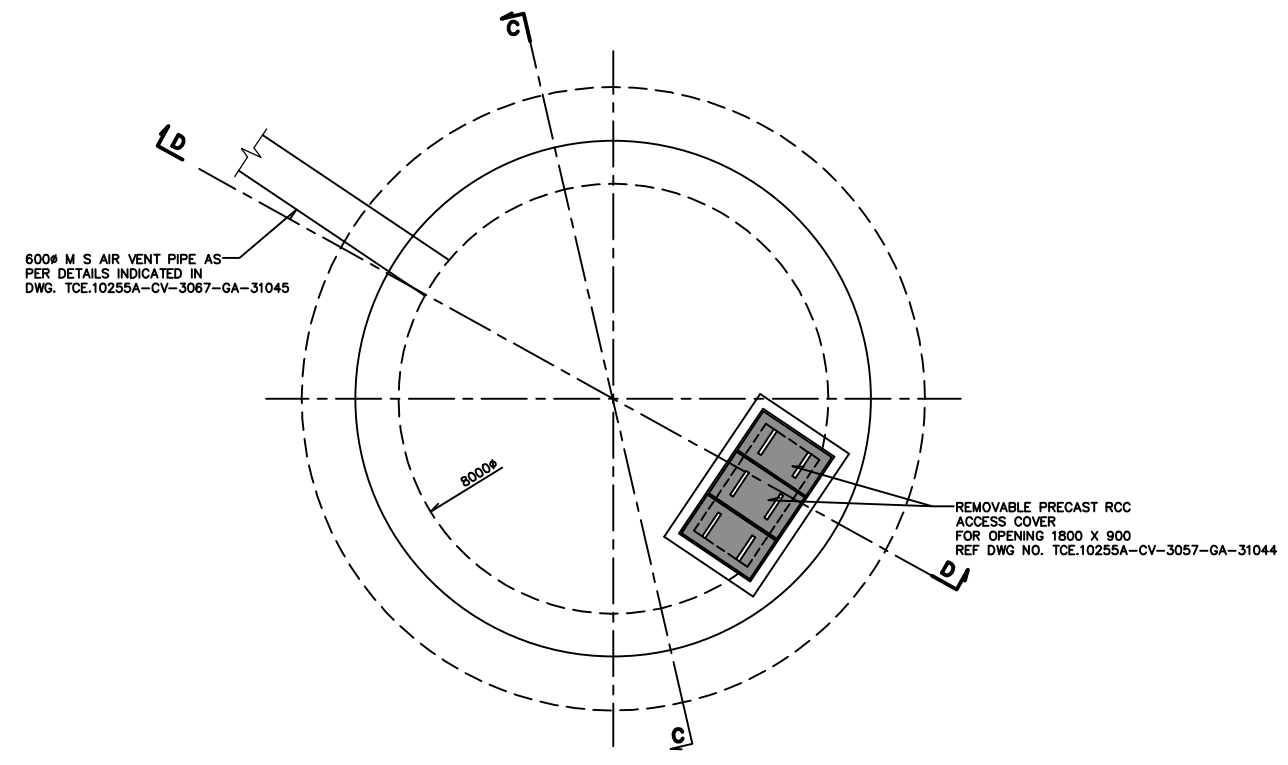

SECTIONAL PLAN A-A
1:50

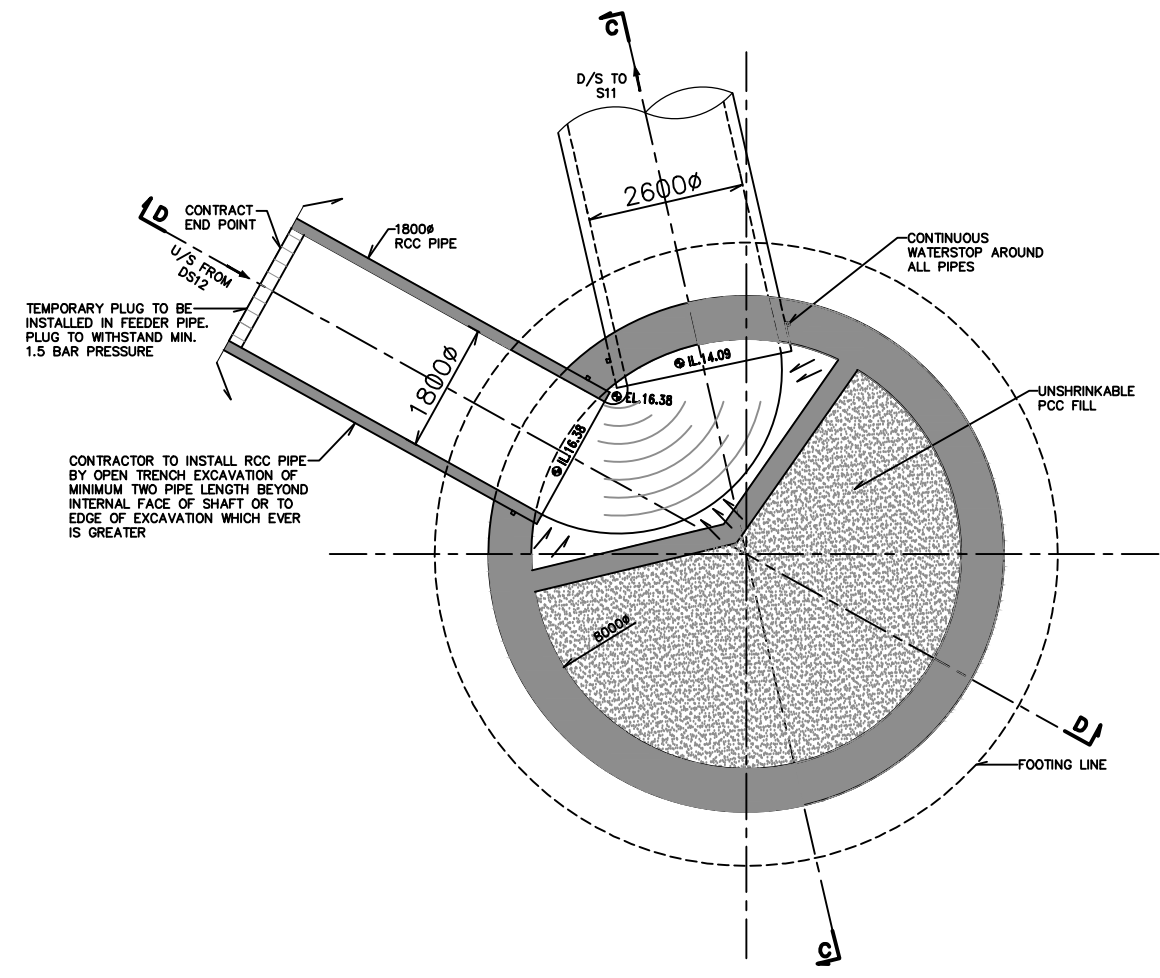

SECTIONAL PLAN B-B
1:50

SIGN.													
INITIALS													
REVISIONS													
SIGN.													
INITIALS													
REVISIONS													
SIGN.													
INITIALS													
REVISIONS													
SIGN.													
INITIALS													
REVISIONS													
P1													
INITIALS	MMS	CB	CB	CB			AR			SVP	SVP		08-04-2019
REVISIONS													
P0													
INITIALS	MMS	CB	CB	CB			AR			SVP	SVP		04-08-2018
REVISIONS													
ISSUE	DRN	DSN	CHD	CV	EL	IC	ME	CLEARED			PE/PM	APPD	DATE

TENDER PURPOSE ONLY
 SCALE AS SHOWN

P (PRELIMINARY) ISSUES ARE NOT TO BE USED FOR CONSTRUCTION / FABRICATION BUT ARE ISSUED FOR LIMITED PURPOSES ONLY AS INDICATED IN THE SMALL BLOCK ABOVE THIS BLOCK.

CONSTRUCTION / FABRICATION WORK IS PERMITTED ON *R* (RELEASED) ISSUES ONLY.

INFORMATION CONTAINED WITHIN 'HOLD' IS NOT RELEASED FOR CONSTRUCTION / FABRICATION. FIELD MUST GET DESIGN OFFICE TO CLEAR 'HOLDS' IN TIME BEFORE PROCEEDING WITH ANY CONSTRUCTION / FABRICATION WORK RELATED TO 'HOLDS'.

Proprietary rights of the information contained herein belong to TCE. This information is intended to be used for the mentioned purpose/project only. In case of misuse of information and any claim arising thereof, cost and consequence will be on the party misusing the information.

FILE NAME : TCE.10255A-CV-3057-GA-31037

MUNICIPAL CORPORATION OF GREATER MUMBAI
 MUMBAI SEWAGE DISPOSAL PROJECT STAGE II-PRIORITY WORKS
 PRIORITY SEWER TUNNEL - PHASE 2 (PST II)
 GENERAL ARRANGEMENT
 TUNNEL SHAFT S12 (SECTIONAL PLAN)

TATA CONSULTING ENGINEERS LIMITED
 MUMBAI